

**PNEUTORQUE<sup>®</sup>**  
**PTM, PTME & TRUKTORQUE<sup>™</sup> SERIES**  
**STALL TOOLS**

**OPERATORS HANDBOOK (PART NO. 34321) Issue 3**  
Original Instructions (ENGLISH)

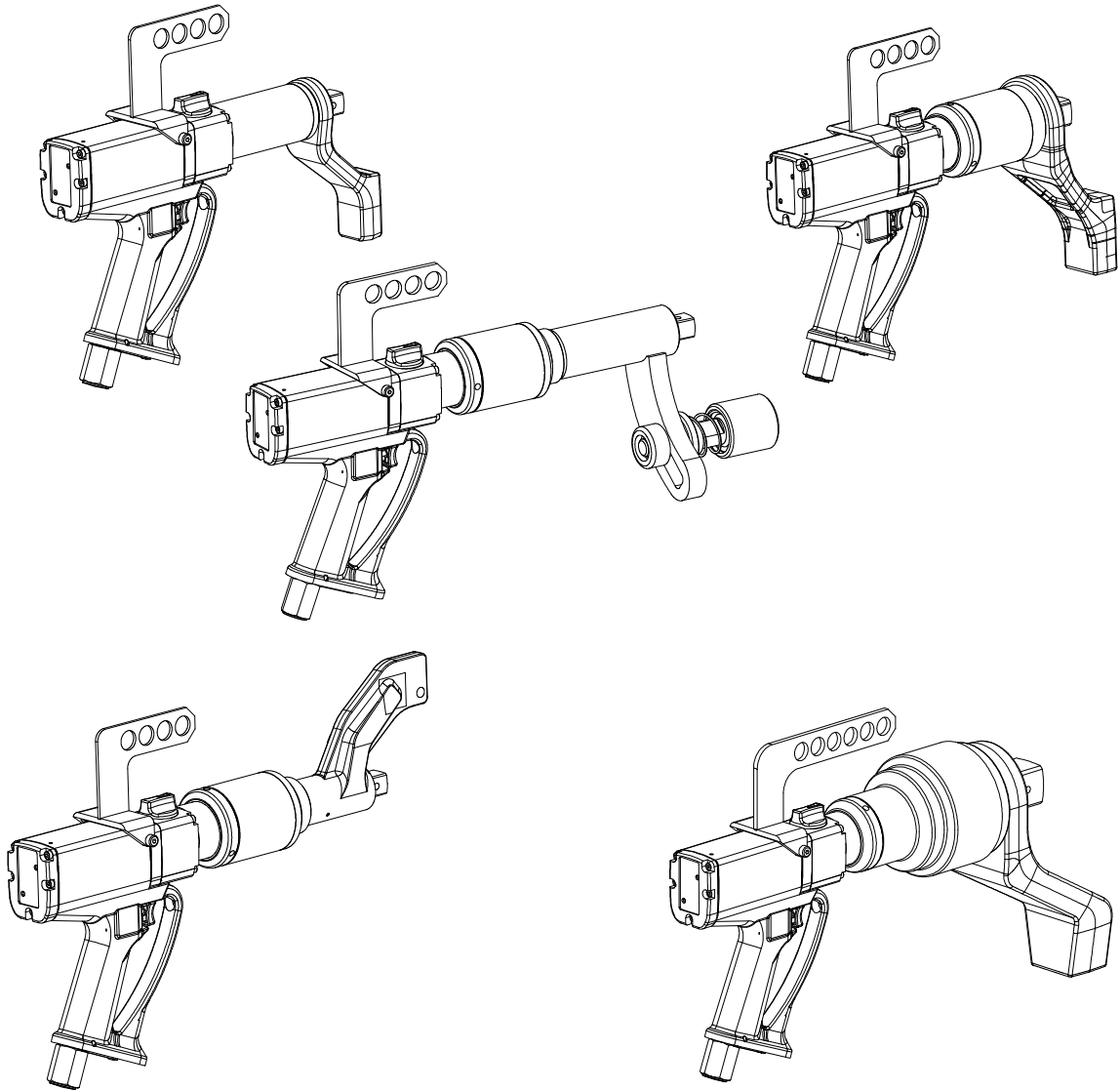



## CONTENTS

	<u>PAGE</u>
<b>Part Numbers Covered By This Handbook</b>	<b>2</b>
<b>Safety</b>	<b>3</b>
<b>Introduction</b>	<b>4</b>
<b>Features And Functions</b>	<b>6</b>
<b>Set Up Instructions</b>	<b>7</b>
<b>1. Pneutorque® Hanger</b>	<b>7</b>
<b>2. Connecting Air Supply</b>	<b>7</b>
<b>3. Air Lubrication</b>	<b>8</b>
<b>4. Torque Reaction</b>	<b>8</b>
<b>5. Clockwise / Counter Clockwise Operation</b>	<b>11</b>
<b>6. Setting Torque To Tighten Fastener</b>	<b>11</b>
<b>Operating Instructions</b>	<b>12</b>
<b>Maintenance</b>	<b>14</b>
<b>Specification</b>	<b>16</b>
<b>Declaration Of Conformity</b>	<b>18</b>
<b>Trouble Shooting</b>	<b>19</b>
<b>Glossary Of Terms</b>	<b>19</b>

## PART NUMBERS COVERED BY THIS HANDBOOK

This handbook covers the setup and use of Norbar Pneutorque® PTM, PTME & TrukTorque™ stall tools.

PART NUMBER	MODEL	DIRECTION	MAXIMUM TORQUE
18100.F06	PTM-52-500-F	Forward (Clockwise) only.	500 N.m
18100.B06	PTM-52-500-B	Bi-directional.	
18101.F06	PTM-52-800-F	Forward (Clockwise) only.	800 N.m
18101.B06	PTM-52-800-B	Bi-directional.	
18102.F06	PTM-72-1000-F	Forward (Clockwise) only.	1000 N.m
18102.B06	PTM-72-1000-B	Bi-directional.	
18162.B06	TrukTorque™	Bi-directional.	1000 N.m
18162.B08	TrukTorque™	Bi-directional.	1000 N.m
18103.F08	PTM-72-1350-F	Forward (Clockwise) only.	1350 N.m
18103.B08	PTM-72-1350-B	Bi-directional.	
18163.B08	TrukTorque™	Bi-directional.	1350 N.m
18104.F08	PTM-72-2000-F	Forward (Clockwise) only.	2000 N.m
18104.B08	PTM-72-2000-B	Bi-directional.	
18106.F08	PTM-92-2700-F	Forward (Clockwise) only.	2700 N.m
18106.B06	PTM-92-2700-B	Bi-directional.	
18107.F08	PTM-92-3500-F	Forward (Clockwise) only.	3500 N.m
18107.B08	PTM-92-3500-B	Bi-directional.	
18107.F12	PTM-92-3500-F	Forward (Clockwise) only.	
18107.B12	PTM-92-3500-B	Bi-directional.	
18108.F12	PTM-119-4500-F	Forward (Clockwise) only.	4500 N.m
18108.B12	PTM-119-4500-B	Bi-directional.	
18109.F12	PTM-119-6000-F	Forward (Clockwise) only.	6000 N.m
18109.B12	PTM-119-6000-B	Bi-directional.	
18140.F06	PTME-72-1000-F	Forward (Clockwise) only.	1000 N.m
18140.B06	PTME-72-1000-B	Bi-directional.	
18141.F08	PTME-72-2000-F	Forward (Clockwise) only.	2000 N.m
18141.B08	PTME-72-2000-B	Bi-directional.	

**NOTE: THE MAIN PTM, PTME TRUKTORQUE MODELS ARE LISTED ABOVE. OTHER PTM, PTME & TRUKTORQUE STALL TOOLS WITH MINOR VARIANCES ARE ALSO COVERED.**

Description of options:

PART NUMBER OPTION	DESCRIPTION
****.F**	Forward (Clockwise) only.
****.B**	Bi-directional (Clockwise and Counter Clockwise).
****.*06	3/4" A/F drive square size.
****.*08	1" A/F drive square size.
****.*12	1 1/2" A/F drive square size.

MODEL OPTION	DESCRIPTION
PTM_**_****_*	Pneutorque Twin Motor.
PTME_**_****_*	Pneutorque Twin Motor fixed nose extension.
PTM*-52-****_*	52mm diameter gearbox.
PTM*-72-****_*	72mm diameter gearbox.
PTM*-92-****_*	92mm diameter gearbox.
PTM*-119-****_*	119mm diameter gearbox.
PTM*_**_1000_*	Maximum torque in N.m.
PTM*_**_****_-F	Forward (Clockwise) only.
PTM*_**_****_-B	Bi-directional (Clockwise and Counter Clockwise).

## SAFETY

**IMPORTANT: DO NOT OPERATE THE TOOL BEFORE READING THESE INSTRUCTIONS. FAILURE TO DO SO MAY RESULT IN PERSONAL INJURY OR DAMAGE TO THE TOOL.**

This tool is intended for use with threaded fasteners.

The use of ear protectors is recommended.

Do not use these tools in potentially explosive atmosphere as they contain grease, which may cause an explosion hazard in the presence of pure oxygen. These tools also contain aluminium alloy components which may cause a hazard in certain explosive environments.

Unexpected tool movement due to reaction forces or breakage of drive square or reaction bar may cause injuries.

Isolate the tool from all energy sources before changing or adjusting the drive square or socket.



There is a risk of crushing between the reaction bar and work piece.  
Keep hands away from reaction bar.  
Keep hands away from tool output.

Keep loose clothing, hair, etc. from being caught in any rotating part of the tool.

These tools require a reaction bar. See section on Torque Reaction.

Ensure all hoses are correctly fitted before switching on the mains air supply. This avoids the risk of injury by whipping air hoses.

Unexpected direction of drive square movement can cause a hazardous situation.

Use only sockets and adaptors which are in good condition and are intended for use with power tools.

Pneutorque® Wrenches are non-impacting, torque controlled threaded fastener tightening tools and must always be operated with the following:-

- Clean dry air supply with a minimum flow of 19 litres/sec (40 CFM).
- Lubro Control Unit or similar Filter, Regulator and Lubricator Unit 1/2" Bore (12 mm).
- Impact or high quality sockets.
- Reaction bar.

## INTRODUCTION

The Pneutorque® PTM, PTME & TrukTorque™ tools are air driven power tools designed for applying torque to threaded fasteners. There are models to cover torque capacities of 500 N.m to 2000 N.m. The tools use an external air pressure regulator (included in a Lubro Control Unit) to set the air pressure that controls the stall torque.

**TIP.** Pneutorque® tools are also available with integral transducers. These measure the applied torque and shut off the air supply when a set value is reached; see Norbar or a Norbar distributor for further details.

**PARTS INCLUDED:-** \_\_\_\_\_

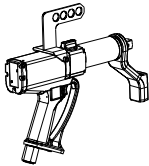
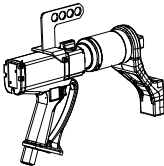
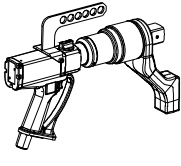
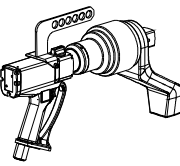
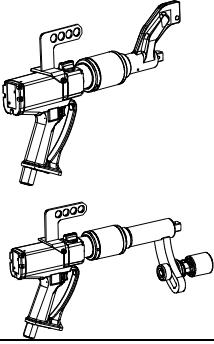
DESCRIPTION:	PART NUMBER				
	PTM-52	PTM-72	PTM-92	PTM-119	PTME-72 / TrukTorque
Visual difference.					
Pneutorque® power tool	18100.** 18101.**	18102.** 18103.** 18104.**	18106.** 18107.**	18108.** 18109.**	18140.** 18141.** 18162.** 18163.**
Cranked reaction bar	18646	18494	18936	18961	-
Reaction bar retaining circlip	26588	26486	26486	26482	-
Hanger	18747	18747	18971	18971	18747
Operators handbook (with air pressure graph & language CD [if required])	34321	34321	34321	34321	34321

**ACCESSORIES:-**

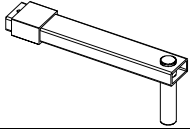
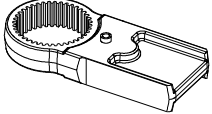
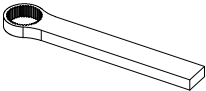
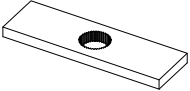
DESCRIPTION:	PART NUMBER:					
	PTM-52	PTM-72	PTM-92	PTM-119	PTME-72	TrukTorque
Lubro Control Unit	16074	16074	16074	16074	16074	16074
3/4" Drive Square (fixing screw)	18544 (25351.30)	18779 (25352.45)	-	-	-	-
1" Drive Square (fixing screw)	18545 (25351.30)	18492 (25352.45)	18934 (25352.60)	-	-	-
1 1/2" Drive Square (fixing screw)	-	-	18935 (25352.60)	18959 (25352.80)	-	-
3/4" Drive Shaft (fixing pin)	-	-	-	-	77112.2 (26287)	-
1" Drive Shaft (fixing pin)	-	-	-	-	18802 (26287)	-
Reaction Bar [NOTE 1] 	18298	18298	-	-	-	-
Reaction Bar Adaptor [NOTE 1] 	18558	18290	-	-	-	-
Single-sided Reaction Plate 	18576	18292	18979	16687	-	-
Double-sided Reaction Plate 	18590	18293	18980	18981	-	-
Silencer	18591	18591	18591	18591	18591	18591
6" Blade Nose Extension	(3/4") 18594.006	(1") 18755.006	-	-	-	-
9" Blade Nose Extension	(3/4") 18594.009	(1") 18755.009	-	-	-	-
12" Blade Nose Extension	(3/4") 18594.012	(1") 18755.012	-	-	-	-
9" TrukTorque™ Nose Extension	-	(3/4") 19087.009 (1") 19089.009	-	-	-	-
12" TrukTorque™ Nose Extension	-	(3/4") 19087.012 (1") 19089.012	-	-	-	-

**NOTE 1: REQUIRES BOTH 'REACTION BAR' AND 'REACTION BAR ADAPTOR' TO BE USED TOGETHER.**

## FEATURES AND FUNCTIONS

### TWIN MOTOR

The tools use two motors; one to quickly run-down the fastener and the other to achieve final torque.

### TRIGGER

The trigger controls the flow of air. The more the trigger is pressed the more air flows into the tool. This allows for slow positioning of socket and reaction bar. Once positioning is complete, the trigger must be fully pressed for correct torque application.

### CLOCKWISE / COUNTER-CLOCKWISE SELECTOR

Tools fitted with this option can be used for tightening counter-clockwise threaded fasteners and for releasing clockwise threaded fasteners.

### REACTION BAR

The reaction bar ensures all reaction forces are contained, so that torque reaction is not passed back to the operator. Several reaction bar styles are available, including the PTME / Nose Extension reaction where tool access is restricted including applications on wheel nuts on heavy vehicles.

### NON-IMPACTING

Low vibration levels make these tools comfortable and safe for the operator to use. In addition there is less damage to the tool, socket and threaded assembly.

### REPLACEABLE DRIVE SQUARE

To avoid internal damage to the tool (especially due to torque overload), the output drive square has been designed to shear first. Pneutorque® tools are fitted with a drive square that can easily be replaced; alternative drive square sizes are also available.

### HANGER

The hanger can be used to suspend the Pneutorque® from a balancer.



## SET UP INSTRUCTIONS

The Pneutorque® set up covers the following items:

1. Pneutorque® Hanger
2. Connecting Air Supply
3. Air Lubrication
4. Torque Reaction
5. Clockwise / Counter Clockwise Operation
6. Setting torque to tighten fastener

Please complete the set up in the order shown.

### 1. PNEUTORQUE® HANGER

The Pneutorque® hanger (Figure 1-E) is designed to be used with a suitable balancer to provided comfortable tool use. If not required the hanger can be removed.

### 2. CONNECTING AIR SUPPLY



**WARNING:** TO AVOID HAZARD FROM WHIPPING AIR HOSES MAKE ALL CONNECTIONS TO THE TOOL BEFORE TURNING ON THE AIR SUPPLY.

- 2.1 Make sure all hoses are clean, in good condition and free from dirt / water.
- 2.2 Connect the tool air inlet hose (Figure 1-C) to the outlet side of the lubro control unit (Figure 1-B) (not supplied), observing air flow direction arrows.

**TIP.** To connect the air inlet hose to a 1/2" bore hose use a 1/2" BSP Male/Male connector. A pair of spanners will be required to perform this task (22mm (7/8") A/F and 24mm (15/16") A/F open-ended spanners)

- 2.3 Connect the inlet side of the lubro control unit (Figure 1-B) to the mains air supply (Figure 1-A) using a minimum hose size of 1/2" bore (12mm). Avoid using 1/2" bore hoses of longer than 5 meters from the supply to the pressure regulator unit as this will reduce the performance of the tool.
- 2.4 Turn on air supply and check for air leaks.

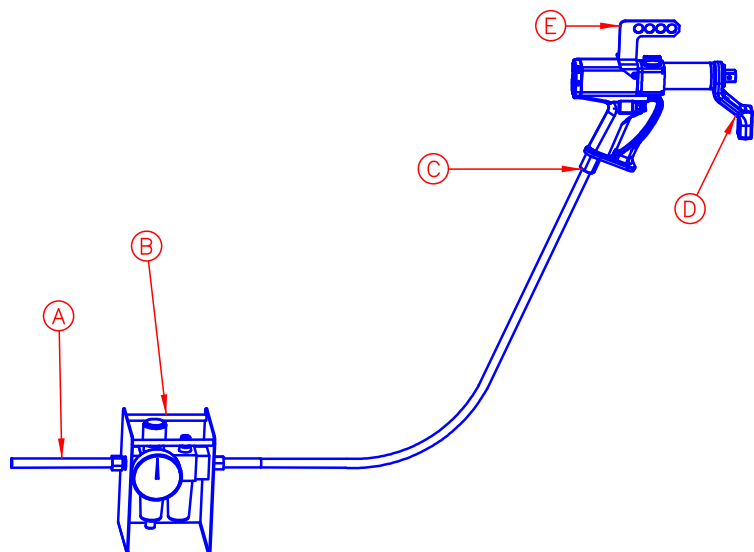

Figure 1 – Connections

**3. AIR LUBRICATION**

The tool must be used with oil lubrication in the supplied air, this is achieved by using a Lubro Control Unit (not supplied).

Set the air lubrication:

- a. Fill Lubro Control Unit with hydraulic oil (Shell Tellus 15 or equivalent good quality hydraulic oil).
- b. Ensure the tool drive is free to rotate.
- c. Run the tool by pressing the trigger.
- d. Adjust Lubro Control Unit to supply 6 drops of oil per minute.
- e. Release trigger.

See Lubro Control Unit handbook for more details.

**4. TORQUE REACTION**

The reaction bar ensures all reaction forces are contained, so torque reaction is not passed back to the operator. Several reaction bar styles are available.

Fit reaction bar as detailed below:

TOOL TYPE	REACTION BAR TYPE	FITTING INSTRUCTIONS
PTM	Cranked reaction bar (standard)	Fit reaction bar / plate (Figure 1-D) over the drive square to engage reaction splines. Secure with circlip supplied.
	Single sided reaction plate (option)	
	Double sided reaction plate (option)	
	Nose Extension (option)	Fit as instructions supplied with nose extension.
PTME	Nose Extension (Standard)	Factory fitted, not removable.
TrukTorque	Nose Extension (Standard)	Factory fitted, not removable.

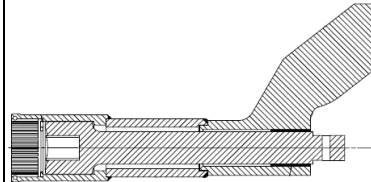

It is essential the reaction bar rests squarely against a solid object or surface adjacent to the fastener to be tightened. The contact area must be within the shaded area of figure 2, with the contact area as large as possible.

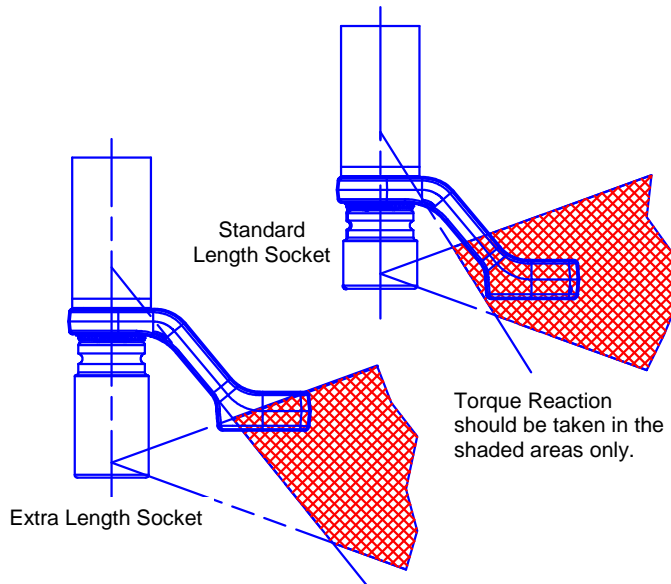

Figure 2– Safe reaction window



**WARNING: CARE MUST BE TAKEN TO ENSURE THAT THE REACTION BAR IS ONLY USED WITHIN THE LIMITATIONS SHOWN IN FIGURE 2.**

For special applications or where extra deep sockets must be used the standard bar may be extended but only within the limitations shown on Figure 2. Alternative reaction bars are available, see page 5.



**WARNING: FAILURE TO OBSERVE THE LIMITATIONS SHOWN IN FIGURE 2 WHEN MODIFYING STANDARD REACTION BARS MAY RESULT IN PREMATURE WEAR OR DAMAGE TO THE TOOL.**

Standard drive square extensions MUST NOT be used as these will cause serious damage to the tool output drive. A range of nose extensions is available for applications where access is restricted. These are designed to support the final drive correctly.

The dimensions of the standard reaction bars is shown in the following table:

REACTION BARS (STANDARD)		TOOL	'L'	'A'	'B'	'W'	'SQ'
	PTM-52		60	131	71	35	3/4"
	PTM-72		75	165	91	48	1"
	PTM-92		98.5	205	115	50	1" 1 1/2"
	PTM-119		127	199	65	55	1 1/2"
REACTION BARS (PTME)		TOOL	'L'	'A'	'B'	'W'	'SQ'
	PTME-72 (1000 N.m)		80.5	110	63	12	3/4"
	PTME-72 (2000 N.m)		51.5	110	62	16	1"

REACTION BARS (TrukTorque)	TOOL	L	A	B	C	ØD	ØE	SQ
	TrukTorque 1000 N.m	98	47	132.5	29	52	38	3/4" 1"
	TrukTorque 1350 N.m	98	47	132.5	29	52	38	1"

When the Pneutorque® is in operation the reaction bar rotates in the opposite direction to the output drive square and must be allowed to rest squarely against a solid object or surface adjacent to the fastener to be tightened. (See figure 3).

PNEUTORQUE® TYPE	TORQUE REACTION	
	Clockwise	Counter-clockwise (Bi directional tools only)
Example of PTM tool.	<p>Figure 3(a)</p>	<p>Figure 3(b)</p>
Example of PTM tool with nose extension option, PTME tool or TrukTorque.	<p>Figure 3(c)</p>	<p>Figure 3(d)</p>



**WARNING:** ALWAYS KEEP HANDS CLEAR OF THE REACTION BAR WHEN THE TOOL IS IN USE OR SERIOUS INJURY MAY RESULT.



**5. CLOCKWISE/COUNTER-CLOCKWISE OPERATION**

Set clockwise / counter-clockwise as required.

**NOTE: THIS SETTING ONLY APPLIES TO BI-DIRECTIONAL TOOLS.**

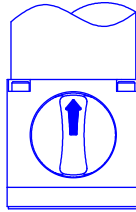

**Figure 4(a) – Clockwise**  
(Arrow towards drive square)

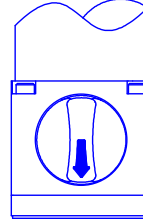

**Figure 4(b) – Counter-clockwise**  
(Arrow away from drive square)



**WARNING: FAILURE TO FULLY ENGAGE THE CLOCKWISE/COUNTER-CLOCKWISE OPERATION SELECTOR WILL RESULT IN DAMAGE TO THIS PART OF THE GEARBOX.**

**6. SETTING TORQUE TO TIGHTEN FASTENER**

The torque created by the Pneutorque® depends on the air pressure setting. All tools are supplied with an Air Pressure Graph that gives the air pressure required to produce the correct torque output.

Set the torque output as follows:-

1. Use the Air Pressure Graph (supplied) to find the air pressure to achieve the required torque.

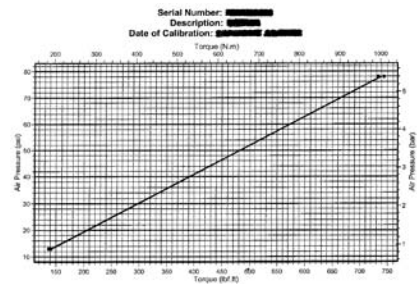

2. With the tool running, adjust the Lubro Control Unit until the correct air pressure is shown on the gauge.

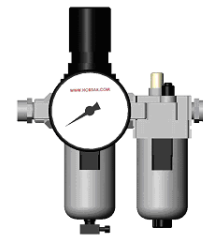

**IMPORTANT: THE WRENCH MUST BE FREE RUNNING WHILE ADJUSTING THE AIR PRESSURE TO GIVE THE CORRECT SETTING.**

**IMPORTANT: CHECK THAT THE LUBRO CONTROL UNIT IS SUPPLYING APPROXIMATELY SIX DROPS OF OIL PER MINUTE WHILE THE TOOL IS FREE RUNNING.**

## OPERATING INSTRUCTIONS



**WARNING: KEEP HANDS CLEAR OF THE REACTION BAR.**



**WARNING: WHEN USING THIS TOOL IT MUST BE SUPPORTED AT ALL TIMES IN ORDER TO PREVENT UNEXPECTED RELEASE IN THE EVENT OF FASTENER OR COMPONENT FAILURE.**

### A. TIGHTENING

1. Fit Pneutorque® with the correct size impact or high quality socket to suit fastener.

**TIP:** For added safety it is recommended to secure the socket to the drive square. This is often achieved using a pin and O ring, see socket manufacturer for guidance.

2. Ensure the Clockwise/Counter-clockwise selector is correctly set (if fitted).
3. Rotate the handle into a convenient position relative to the reaction bar. Fit the tool onto the fastener to be tightened with the reaction bar adjacent to the reaction point. See Figure 5.
4. Adopt a suitable posture to counteract normal or unexpected movement of the tool due to reaction forces.
5. Squeeze the trigger partially to bring the reaction bar into contact with the reaction point.
6. Fully press trigger and keep fully pressed until tool stalls then release trigger. If the trigger is not fully pressed full torque will not be applied to the fastener.
7. Remove the tool from the fastener.

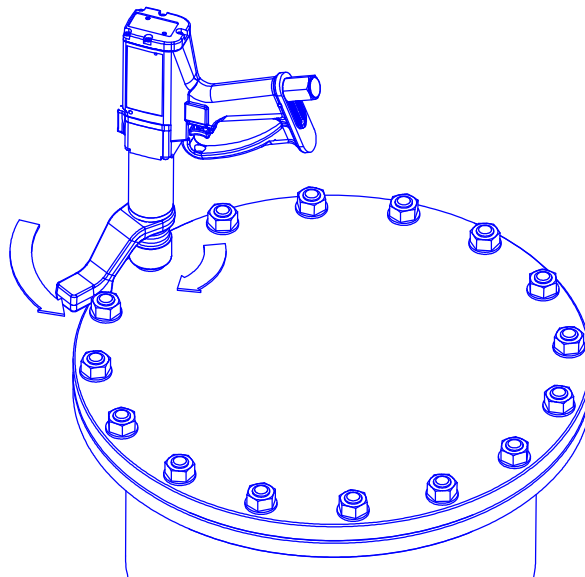

**Figure 5**

**B. RELEASING****NOTE: ONLY FOR BI-DIRECTIONAL TOOLS**

1. Fit the Pneutorque® with the correct size impact or high quality socket to suit the fastener to be released.

**TIP:** For added safety it is recommended to secure the socket to the drive square. This is often achieved using a pin and O ring, see socket manufacturer for guidance.

2. Ensure the clockwise/counter-clockwise selector is correctly set.
3. Rotate the handle into a convenient position relative to the reaction bar. Fit the tool onto the fastener to be released with the reaction bar adjacent to the reaction point. See Figure 6.
4. Adopt a suitable posture to counteract normal or unexpected movement of the tool due to reaction forces.
5. Squeeze the trigger partially to bring the reaction bar into contact with the reaction point.
6. Fully press trigger and keep fully pressed until threaded fastener releases.

**TIP:** If unable to release the fastener increase the air pressure to the tool. Do not exceed the maximum air pressure for the tool.



**WARNING: EXCEEDING THE MAXIMUM AIR PRESSURE WILL CAUSE OVERLOADING AND MAY LEAD TO SERIOUS DAMAGE.**



**WARNING: CHANGING THE MAINS AIR PRESSURE AFTER SETTING THE PRESSURE REGULATOR WILL CHANGE THE STALL TORQUE VALUE.**

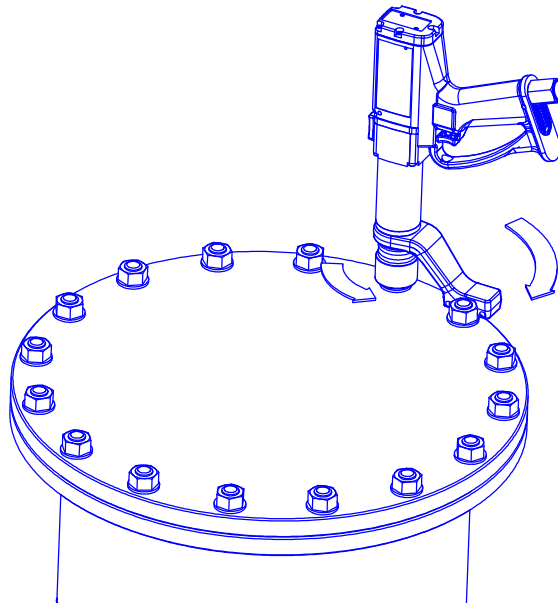

**Figure 6**

## MAINTENANCE

For optimum performance and safety, regular tool maintenance is required. The user maintenance is limited to the replacement of the drive square and the silencer. Any other maintenance or repairs should be carried out by Norbar or a Norbar distributor. Maintenance intervals will depend on the tool usage and the environment in which it is being used. The maximum recommended maintenance & recalibration interval is 12 months.

- TIP:** Steps the user can take to reduce the amount of maintenance required include:
1. Use the tool in a clean environment.
  2. Use an air compressor fitted with a dryer.
  3. Ensure the Lubro Control Unit has sufficient hydraulic oil.
  4. Ensure the Lubro Control Unit delivers hydraulic oil at the correct rate.
  5. Ensure the Lubro Control Unit is regularly maintained, see product handbook.
  6. Maintain the correct torque reaction.

### AIR LUBRICATION:-

Add Shell Tellus 15 or equivalent good quality hydraulic oil to the Lubro Control Unit.

### GEARBOX:-

Under normal operating conditions it is not necessary to re-grease the gearbox. The gearbox contains Lubcon Turm grease Li 802 EP or equivalent good quality grease.

### SILENCER:-

The silencer (part number 18591) must be changed every 12 months. This may be more frequent for high tool usage or dirty environments.

- TIP:** Change silencer with tool upside down, as shown, to ensure internal parts (spring & valve) are kept in place.

1. Remove M4 screw (A) (part number 25381.10) using a 2.5mm hexagon key.
2. Remove pin (B) (part number 26284) using a pin punch.
3. Pull out air inlet tube (D) with base plate & silencer.
4. Remove silencer (E) from air inlet tube.
5. Fit new silencer (part number 18591) over air inlet tube.
6. Fit air inlet tube assembly (C, D & E) into handle against spring resistance.
7. Fit pin (B) with a hammer.
8. Fit screw (A) and torque to 0.5 N.m. Do not over tighten this screw as it is likely to break the base plate moulding.

- TIP:** When refitting air inlet tube assembly into handle care should be taken to ensure correct alignment between air inlet tube & spring. It may be easier to fit the spring into air inlet tube first and secure with a small amount of grease.

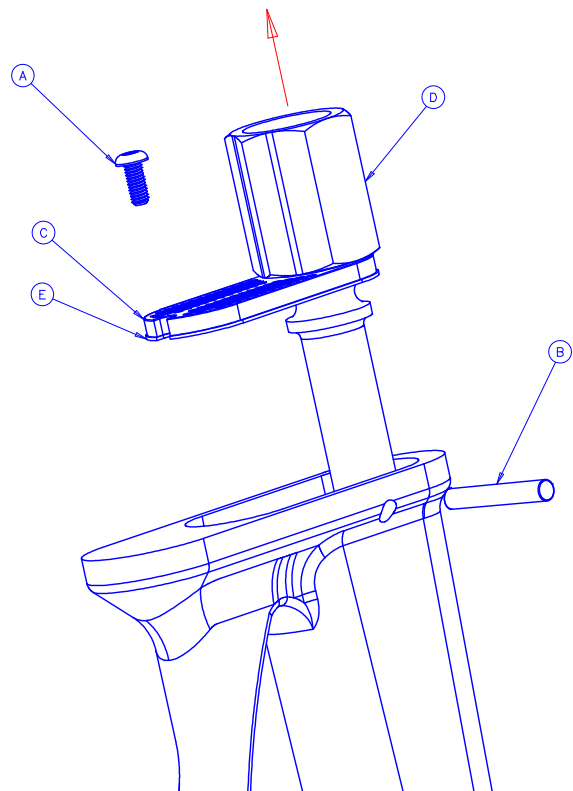
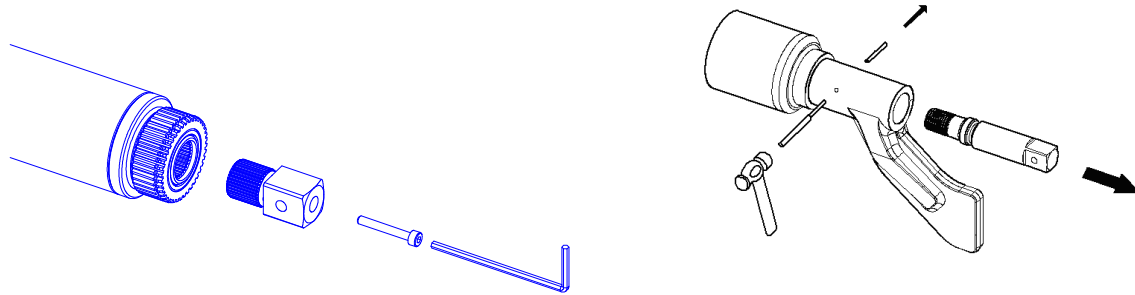

Figure 7 – Silencer replacement



**DRIVE SQUARE:-** \_\_\_\_\_

To avoid internal damage (especially due to torque overload), the output drive square has been designed to shear first. This saves major internal damage and allows easy square removal. For drive square part numbers see page 5.



**Figure 8 – Drive square replacement**

To replace drive square:

1. Remove the air supply.
2. Support tool in a horizontal position
3. Remove the screw or spring pin, then remove drive square.  
If the square has sheared it may be necessary to use pliers to remove the broken parts
4. Fit new drive square.
5. Fit new screw and tighten between 4 N.m to 5 N.m or insert new spring pin.
6. Connect air supply.

**TIP:** If the drive square fails continually then seek advise from Norbar or a Norbar distributor.

**CALIBRATION:-** \_\_\_\_\_

To maintain the Pneutorque® accuracy it is recommended the tool is recalibrated at least every 12 months. Contact Norbar or a Norbar distributor for more information.

**CLEANING:-** \_\_\_\_\_

Keep the tool in a clean condition to aid safety. Do not use abrasives or solvent based cleaners.

**DISPOSAL:-** \_\_\_\_\_

**RECYCLING CONSIDERATIONS**

COMPONENT	MATERIAL
Handle	Aluminium case / Steel internals
Gearbox (Clockwise / Counter clockwise)	Aluminium case / Steel internals
Gearbox (52mm / 72mm)	Steel with nickel plated case / Steel internals
Reaction bar	PTM-52 is steel / PTM-72 is aluminium

## SPECIFICATIONS

PART NUMBER	TORQUE		TOOL SPEED (FREE RUNNING AT MAXIMUM AIR PRESSURE)
	MINIMUM	MAXIMUM	
18100.**	100 N.m (74 lbf.ft)	500 N.m (370 lbf.ft)	245 rev/min
18101.**	160 N.m (118 lbf.ft)	800 N.m (590 lbf.ft)	175 rev/min
18102.** / 18140.** / 18162.**	200 N.m (147 lbf.ft)	1000 N.m (738 lbf.ft)	140 rev/min
18103.** / 18163.**	270 N.m (200 lbf.ft)	1350 N.m (1000 lbf.ft)	105 rev/min
18104.** / 18141.**	400 N.m (295 lbf.ft)	2000 N.m (1475 lbf.ft)	70 rev/min
18106.**	540 N.m (400 lbf.ft)	2700 N.m (2000 lbf.ft)	57 rev/min
18107.**	700 N.m (520 lbf.ft)	3500 N.m (2600 lbf.ft)	41 rev/min
18108.**	900 N.m (660 lbf.ft)	4500 N.m (3300 lbf.ft)	32 rev/min
18109.**	1200 N.m (885 lbf.ft)	6000 N.m (4425 lbf.ft)	25 rev/min

PART NUMBER	DIMENSIONS (mm)					TOOL WEIGHT (kg)		REACTION WEIGHT (kg)
	H	W	R	L		****.F**	****.B**	
				****.F**	****.B**			
18100.**	318	82	60	284	333	3.8	4.1	0.85
18101.**	318	82	60	284	333	3.8	4.1	0.85
18102.**	318	85.7	75	316	365	5.8	6.1	0.7
18103.**	318	85.7	75	316	365	5.8	6.1	0.7
18104.**	318	85.7	75	349	398	6.2	6.5	0.7
18106.**	318	92	98.5	338	387	8.2	8.5	1.35
18107.**	318	92	98.5	338	387	8.2	8.5	1.35
18108.**	318	119	127	407	456	13	13.3	2.1
18109.**	318	119	127	407	456	13	13.3	2.1
18140.**	318	82	51.5	435	484	6.9	7.2	-
18141.**	318	82	51.5	457	506	7.4	7.7	-
18162.**	318	82	82	-	532	-	9.4	-
18163.**	318	82	82	-	532	-	9.5	-

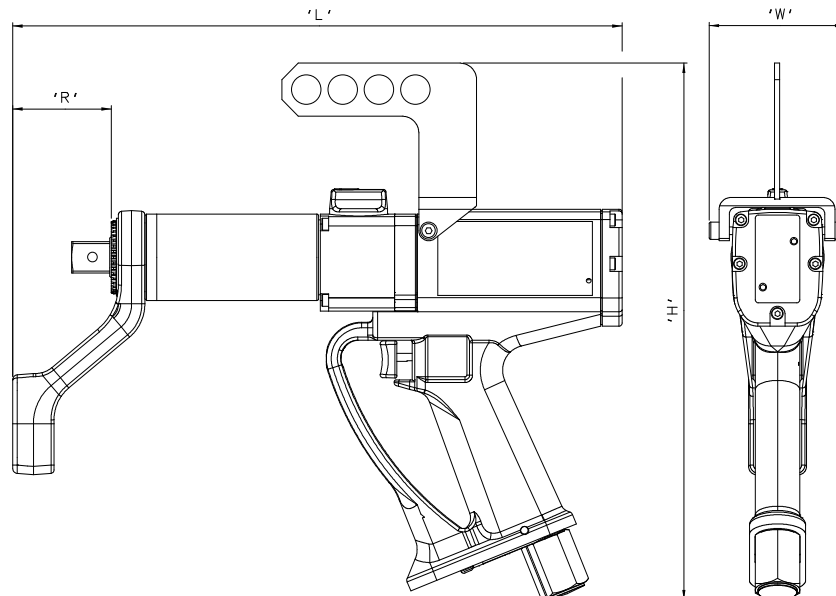

**Figure 9 – Tool Dimensions**

Repeatability:	± 5%
Air Supply:	Maximum pressure – 6.3 bar (For maximum output speed).
Lubrication:	Shell Tellus 15 recommended for the Lubro Control Unit.
Temperature Range:	0°C to +50°C (operating). -20°C to +60°C (storage).
Operating Humidity:	85% Relative Humidity @30°C maximum.
Handle Vibration:	< 2.5 m/s <sup>2</sup> Maximum. Tested in accordance with ISO 8662-7 Hand held portable tools. Measurement of vibrations at the handle.
Sound Pressure Level:	83 dBA measured at 1m equivalent continuous A weighted sound. Tested to BS ISO 3744: 1994 Acoustics. Determination of sound power levels of noise sources using sound pressure. Engineering method in an essentially free field over a reflecting plane. Test conducted in free running condition with a supply pressure of 6.3 bar.
Environment:	Store in a clean & dry environment.
Machinery Directive:	In conformance with: BSEN 792-6:2000 Hand-held non-electric power tools. Safety requirements. Assembly power tools for threaded fasteners.

*Due to continuous improvement all specifications are subject to change without prior notice.*

**NOTE: IF EQUIPMENT IS USED IN A MANNER NOT SPECIFIED BY THE MANUFACTURER, THE PROTECTION PROVIDED BY THE EQUIPMENT COULD BE IMPAIRED.**

## DECLARATION OF CONFORMITY



Norbar Torque Tools Ltd  
Beaumont Road  
Banbury  
Oxfordshire  
OX16 1XJ  
United Kingdom

Tel: + 44 (0) 1295 270333  
Fax: + 44 (0) 1295 753643  
E-mail: [enquiry@norbar.com](mailto:enquiry@norbar.com)

Registered in England No.380480  
VAT No. GB 119 1060 05

QA57  
ISSUE 2  
24.1.97

## Declaration of Conformity

**Manufactured by** Norbar Torque Tools Ltd.,  
Beaumont Road, Banbury, Oxon, OX16 1XJ

### The Directives covered by this Declaration

Safety of Machinery Directive, 2006/42/EC.

### The Equipment Covered by this Declaration

**Equipment:** Pneutorque® PTM, PTME & TrukTorque™ Series Stall Tools.

**Model Name(s):** PTM-52-\*\*\*\*\_\*  
PTM-72-\*\*\*\*\_\*  
PTM-92-\*\*\*\*\_\*  
PTM-119-\*\*\*\*\_\*  
PTME-52-\*\*\*\*\_\*  
PTME-72-\*\*\*\*\_\*  
TrukTorque™

### The Basis on which Conformity is being Declared

The equipment identified above is in compliance with the protection requirements of the above directive, and the following standards have been applied:-

EN 792-6:2000 Hand-held non-electric power tools – Safety requirements.  
Pt 6: Assembly power tools for threaded fasteners.

The technical documentation required to demonstrate that the products meet the requirements of the above Directives has been compiled by the signatory below and is available for inspection by the relevant enforcement authorities. The CE mark was first applied in: 2007.

**Signed:**

*T. M. Lester*

**Full Name:** Trevor Mark Lester B.Eng.

**Date:** 19th October 2010

**Authority:** Compliance Engineer

[www.norbar.com](http://www.norbar.com)

United Kingdom • Australia • United States of America • New Zealand • Singapore • China

## TROUBLE SHOOTING

The following is only a guide, for more complex faults please contact Norbar or a Norbar distributor.

PROBLEM	LIKELY SOLUTIONS
Tool output does not rotate when trigger pressed.	Check air supply is functioning & connected. Check air pressure setting (at least 1 bar). Check correct setting of direction knob. Output drive square sheared, needs replacing. Gear train or air motor is damaged
Drive square sheared.	See maintenance section to replace drive square.
Tool does not stall.	Fastener sheared or thread stripped. Gear train or air motor is damaged

## GLOSSARY OF TERMS

WORD OR TERM	MEANING
A/F	Across Flats.
Air pressure graph	Graph supplied with all stall tools to show the air pressure setting to produce required torque.
Bi-directional	Tool capable of Clockwise & Counter-clockwise square rotation.
Calibration device	Torque measurement system to display peak torque using a joint simulator or test fastener.
Fastener	Bolt or stud to be tightened.
Lubro Control Unit	Unit to provide filtering and lubrication along with pressure regulation. Not supplied with tool.
Nose Extension	A reaction type used where tool access is restricted, typical examples on wheel nuts on heavy vehicles. Available as an option for PTM tools or integral for PTME tools.
Pneutorque®	Product name.
PTM	Pneutorque® Twin Motor.
PTME	Pneutorque Twin Motor with fixed nose extension.
Reaction Bar	Item to counteract applied torque. Also called reaction plate.
Stall Tool	Tool will stall due to air pressure set.
TrukTorque	Pneutorque Twin Motor with fixed nose extension.